

## 小凸缘型

产品特点：与标准型 S8M/H8M 相比，带轮形状发生变化。

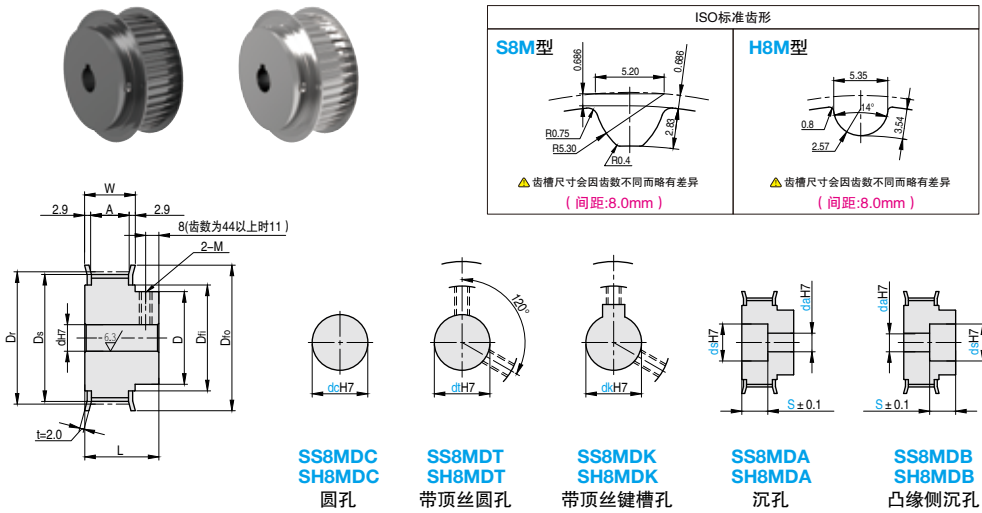

### 订购编号示例

1 代号 - 2 齿数 - 3 宽度代号 - 4 内孔规格 - 5 材料代码 - 6 追加加工代码  
 SS8MDK - 40 - 30 - dk20 - C - CT5

1 代号	2 齿数	4 内孔规格 (单位 1mm)						Dr	Ds	D	Dfo	Dfi
		SS8MDC SH8MDC	SS8MDT SH8MDT	SS8MDK SH8MDK	SS8MDA-SS8MDB SH8MDA-SH8MDB							
		dc	dt	dk	da	ds	S					
SS8MDC SS8MDT SS8MDK SS8MDA SS8MDB	18	12-28	12-22	12-20	12-26	14-28		45.84	44.46	32	52	36
	19	12-31	12-25	12-20	12-29	14-31		48.38	47.01	35	55	40
	20	12-32	12-26	12-22	12-30	14-32		50.93	49.56	36	58	40
	21	12-36	12-30	12-24	12-34	14-36		53.48	52.10	40	61	45
	22	12-37	12-30	12-25	12-35	14-37		56.02	54.65	41	61	45
	24	12-42	12-34	12-28	12-40	14-42		61.12	59.74	46	67	50
	25	12-44	12-36	12-28	12-42	14-44		63.66	62.29	48	70	56
	26	14-47	14-39	14-31	14-45	16-47		66.21	64.84	51	74	58
	28	14-47	14-43	14-35	14-49	16-51		71.30	69.93	55	80	60
	30	14-56	14-46	14-38	14-54	16-56	3.0 ≤ S ≤ L-3.0 (单位 0.1mm)	76.39	75.02	60	87	67
	SH8MDC	32	14-59	14-49	14-45	14-57	16-59	81.49	80.12	63	87	67
	SH8MDT	34	16-66	16-56	16-48	16-64	18-66	86.58	85.21	70	95	75
	SH8MDK	36	16-71	16-61	16-50	16-69	18-71	91.67	90.30	75	99	80
	SH8MDA	38	16-76	16-65	16-50	16-74	18-76	96.77	95.39	80	104	84
	SH8MDB	40	20-80	20-65	20-50	20-79	22-81	101.86	100.49	85	111	90
		44	20-80	20-65	20-50	20-80	22-86	112.05	110.67	90	119	100
		48	20-80	20-65	20-50	20-80	22-95	122.23	120.86	100	127	105
		50	20-80	20-65	20-50	20-80	22-95	127.32	125.95	100	135	115
		60	20-80	20-65	20-50	20-80	22-95	152.79	151.42	100	160	140

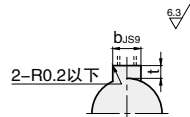

### 键槽尺寸

基本尺寸		键槽尺寸			
内孔型号	公差	b	JS9	t	公差
12		4	±0.0150	1.8	
13-17	+0.018 0	5	±0.0150	2.3	+0.1 0
18		6	±0.0150	2.8	
19-22	+0.021 0	6	±0.0150	2.8	
23-30		8		3.3	
31-38	+0.025 0	10	±0.0180	3.3	+0.2 0
39-44	+0.025 0	12	±0.0215	3.3	
45-50		14		3.8	

### 附件顶丝

孔径	2-M 粗牙螺纹	附件 顶丝
12	M4	M4×3
13-17	M5	M5×4
18-30	M6	M6×5
31-45	M8	M8×6
46-65	M10	M10×8

3 宽度代号	皮带宽度	主要尺寸		
		L	W	A
15	15	37 42(齿数 44-72)	22	17
25	25	48 53(齿数 44-72)	33	28
30	30	53 58(齿数 44-72)	38	33
40	40	64 69(齿数 44-72)	49	44

代号	类型	5 材料代码	材质		表面处理	附件 (顶丝)
			带轮	挡片		
SS8MDC SS8MDT SS8MDK SS8MDA SS8MDB	小凸缘型	A	铝合金	铝合金	本色阳极氧化处理 硬质阳极氧化处理 黑色阳极氧化处理	304
		B				
		C				
		D	45#	SPCC	- 四氧化三铁保护膜 无电解镀锌	35CrMo
		E				
		F				

▲挡片已铆接，带顶丝圆孔、带顶丝键槽孔附带顶丝 ▲圆孔、沉孔、两端沉孔不附带螺纹孔和顶丝

### 6 追加加工类型

变更顶丝角度(90°) A90 | 凸缘切割 FC | 变更螺孔 CT | 加工螺孔(3处) TH3 | 加工螺孔(4处) TH4 | 加工螺孔(6处) TH6 | 加工通孔(3处) SH3 | 加工通孔(4处) SH4 | 加工通孔(6处) SH6

▲加工规格详情、指定方法，请参阅同步带轮追加加工技术信息